



YARD FORCE
OUTDOOR POWER EQUIPMENT

YF60VRX600-BL

600CFM Cordless Blower

OPERATOR'S MANUAL

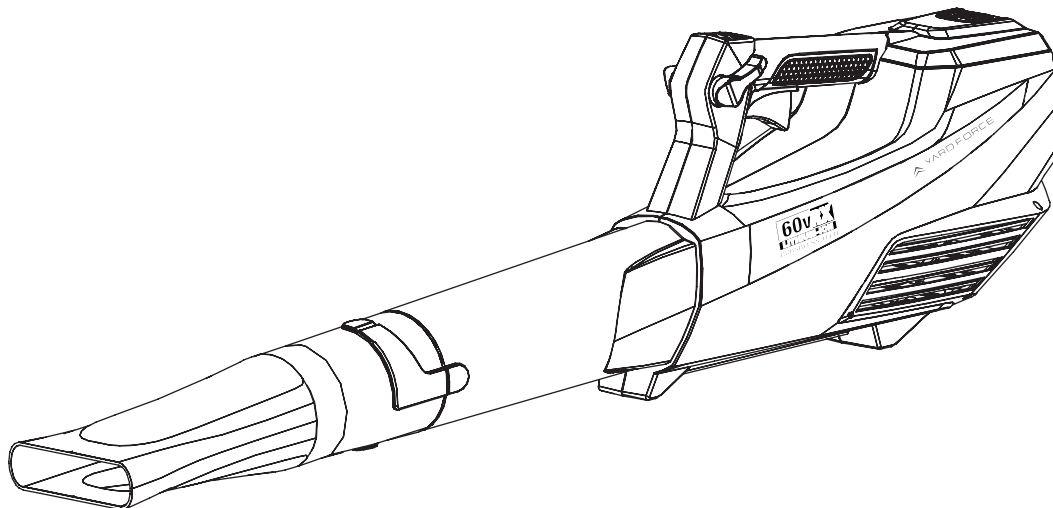

Our Customer Service staff is ready to provide assistance.

In the case of a damaged or missing part, most replacement parts ship directly from Merotec USA in Atlanta or from one of our service partners in the US.

For immediate help with assembly, or for additional product information, email support@MerotecUSA.com or call 866-902-9690 M-F 8:30am – 5:00pm ET. More information can be found on www.YardForceUSA.com.



SAVE THIS MANUAL FOR REFERENCE



You will need this manual for safety instructions, operating procedures, and Warranty. The original sales receipt is required for warranty service.



NOTICE

This YF60vRX Hand-held Tool has a 2-Step Battery Latch

INSTALLATION: The battery latch has 2 positions. Press down firmly until battery is fully inserted. If the battery is not fully inserted and secured in the deepest position #2 the tool will not run.

REMOVAL: Press the release button once, the battery will release from the first latch position. Then hold the battery firmly, press the release button again and pull battery out.

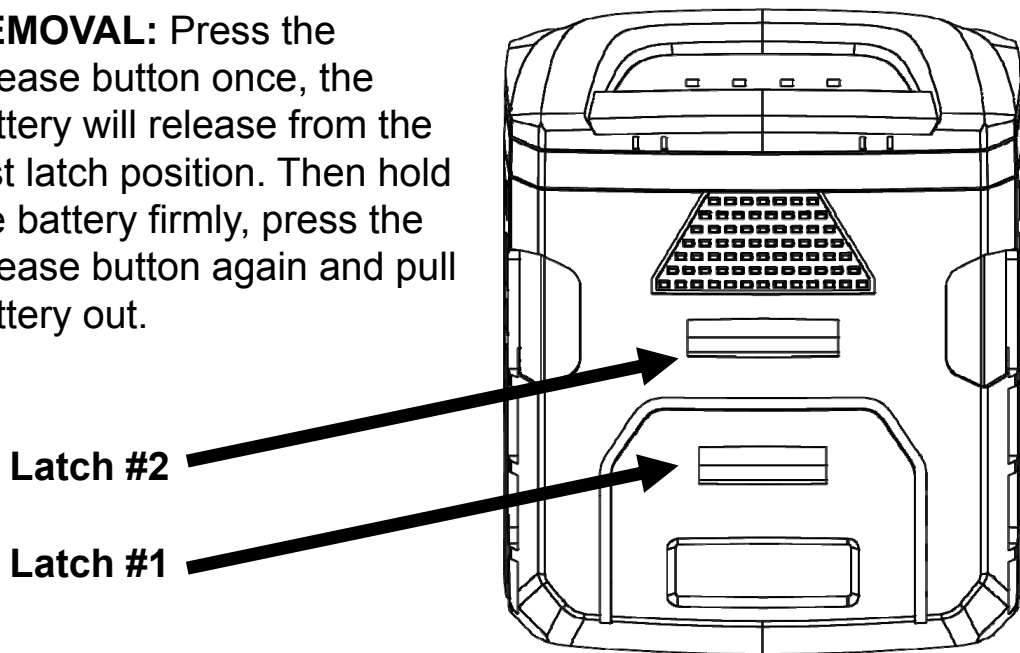

Contact our Customer Care Center in Georgia for help with:

- Product Assembly or Use
- Missing Parts
- Troubleshooting

866-902-9690 M-F 8:30am – 5:00pm ET

You can also visit the Yard Force USA website to download owner's manuals, get product information and request tech support.

www.YardForceUSA.com

TABLE OF CONTENTS

Description of Product Parts	6
Technical Specifications.....	6
Intended use.....	6
Safety Information.....	6
Assembly	11
Adjustment	11
Operation.....	11
Maintenance and Storage	12
Troubleshooting	13
Warranty	14



WARNING

1. To reduce the risk of electric shock- Do not expose to water.
2. Do not use in rain. Store indoors only. Replace damaged battery pack immediately.
3. Disconnect battery pack before cleaning or servicing. Use proper eye protection. Keep away from rotating line.
4. Do not operate without guard in place.
5. Use only 60V Li-ion battery YF60VRX4.0-BAT & YF60VRX2.5-BAT and battery charger YF60VRX4A-CHG & YF60VRX2A-CHG.

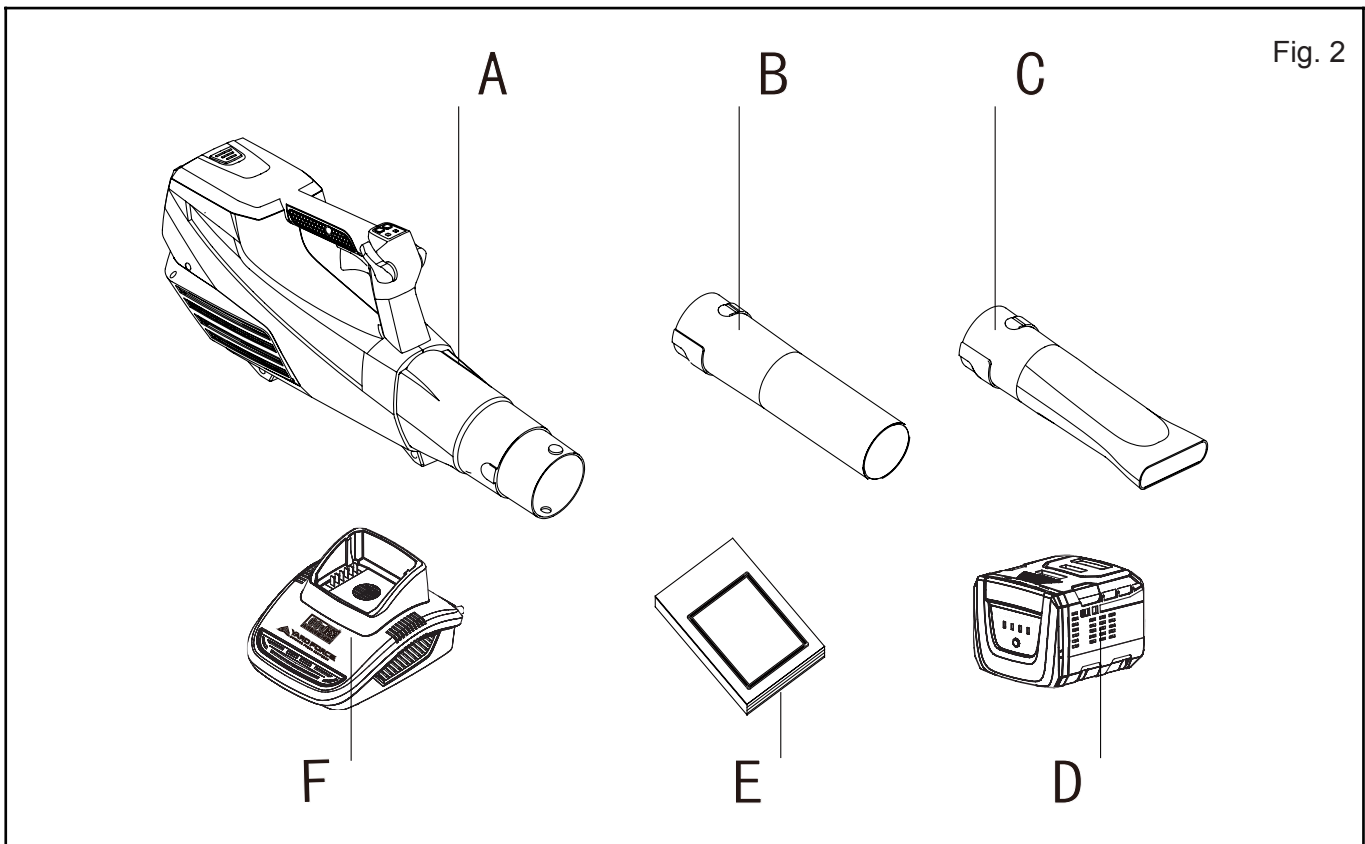
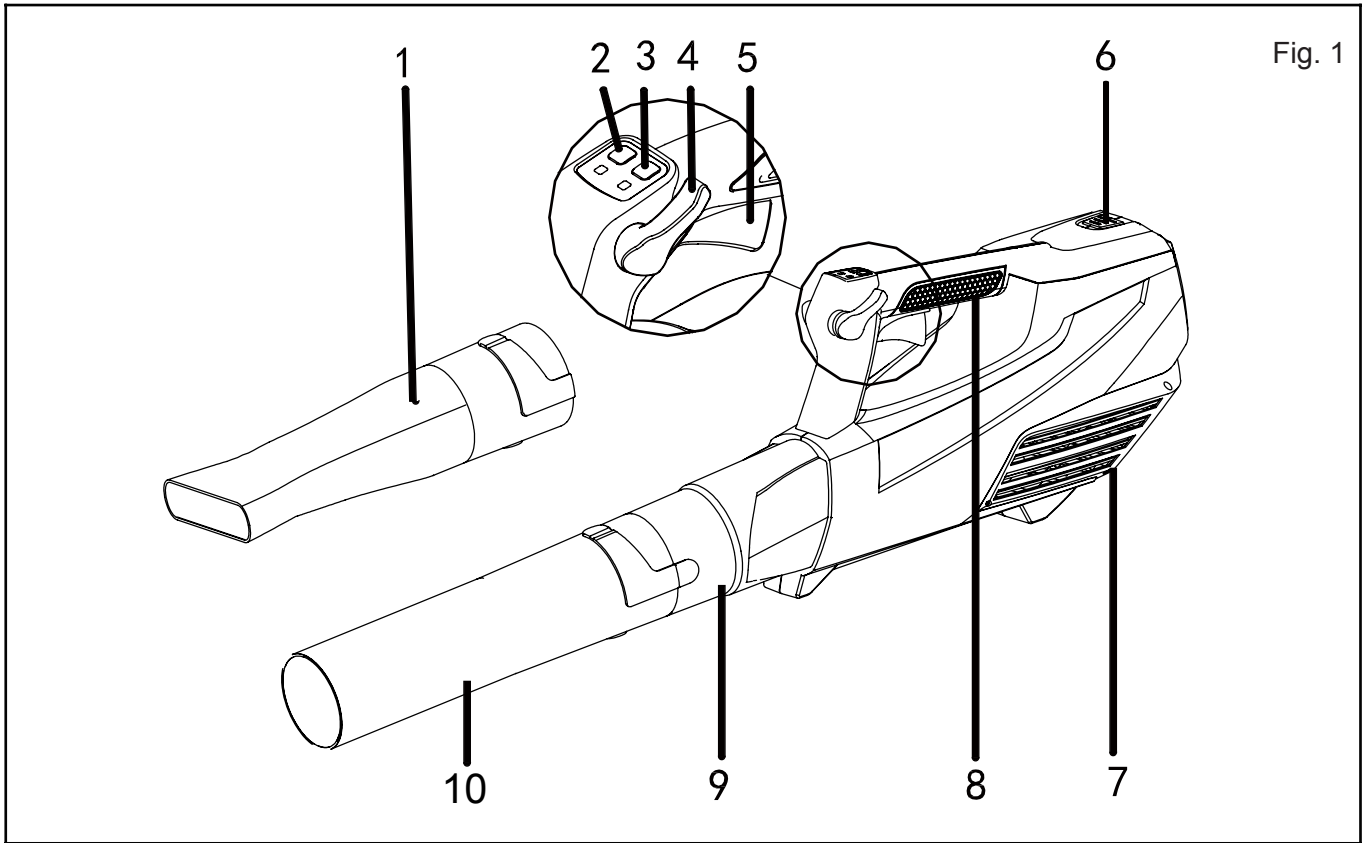

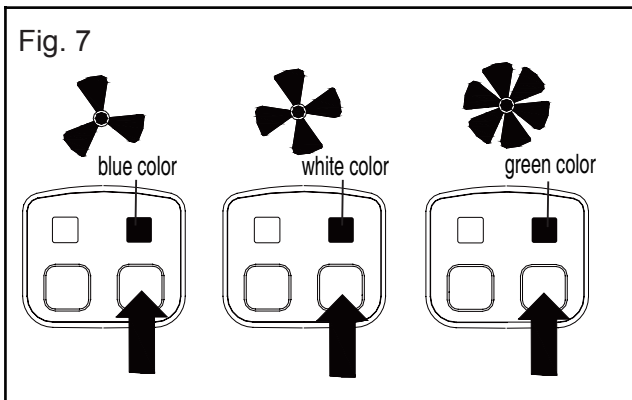
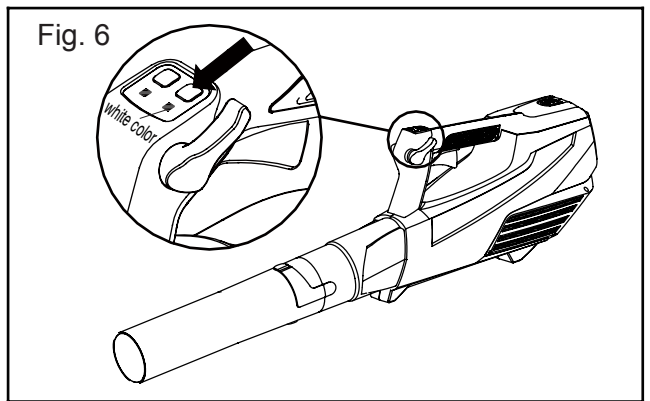
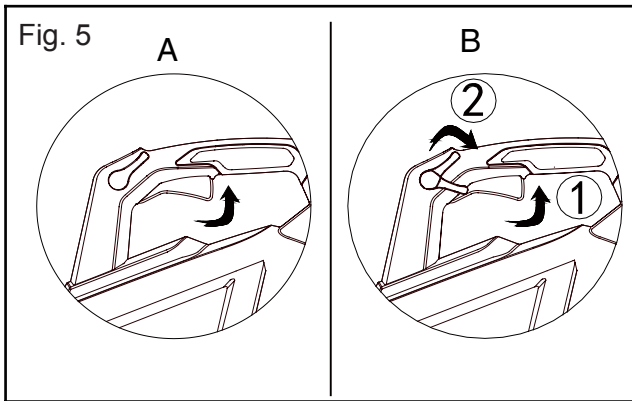
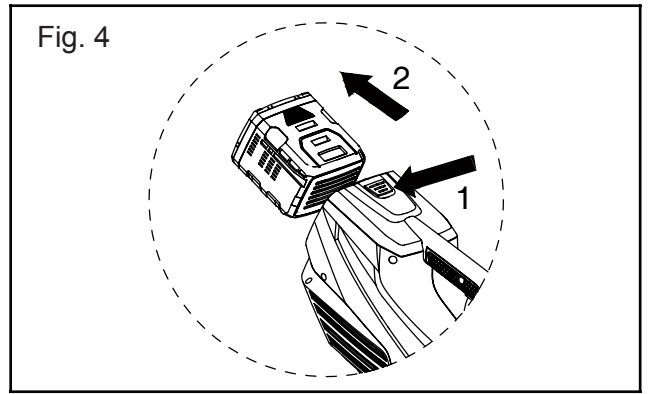
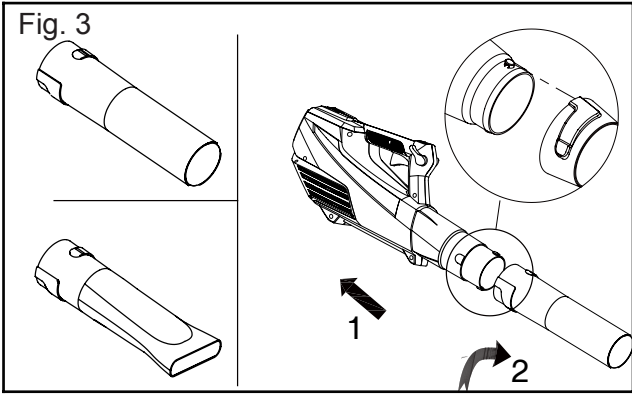

DESCRIPTION OF PRODUCT PARTS

Parts list (See Fig. 1)

1. Flat nozzle
2. Speed adjustment button
3. Turbo button
4. Speed/Cruiser lock lever
5. Trigger switch
6. Battery pack release button
7. Air inlet
8. Main handle
9. Upper tube
10. Lower round nozzle

Carefully remove the machine and parts from its packaging. Identify all the parts packaged in the carton against the parts list. Please contact our customer service center (Monday - Friday 8:30AM - 5:00PM ET) at **(866) 902-9690** if anything is missing.

Delivery parts (See Fig. 2)

- A. Main machine x 1
- B. Lower round nozzle x 1
- C. Lower flat nozzle x 1
- D. Battery pack x 1
- E. Manual x 1
- F. Charger x 1



WARNING: If any parts are damaged or missing, do not operate this tool until the missing parts are replaced. Failure to heed this warning could result in serious personal injury.

NOTE! Always recycle the packaging in accordance with local recycling schemes.

TECHNICAL SPECIFICATIONS

Item No.	YF60VRX600-BL
Voltage/Capacity	60 v d.c. / 2.5 Ah Li-ion
Running Speed	3 Speed settings
Max. Air Speed	150 MPH
Max. Air Volume	600 CFM
Motor	Brushless
Charger	Input: 100~240 V, 50/60 Hz, Output: 63 v d.c. 2.5 A
Charging Time	60 Minutes
Weight	15.4 lbs

Battery pack type	YF60VRX2.5-BAT
Charger type	YF60VRX2A-CHG

INTENDED USE

The blower is intended for use for blow-sweeping leave grass, paper and similar materials, e. g. in gardens, sports stadiums, car parks and driveways. Do not operate your blower indoors. Do not use the blower for any other purpose because of the increased risk of accidents and damage to the blower. Never attempt to modify the blower in any way.

The machine is to be used only for its prescribed purpose. Any other use is deemed to be a case of misuse. The user/operator and not the manufacturer will be liable for any damage or injuries of any kind caused as a result of this.

SAFETY SYMBOLS

The purpose of safety symbols is to attract your attention to possible dangers. The safety symbols and the explanations with them deserve your careful attention and understanding. The symbol warnings do not, by themselves, eliminate any danger. The instructions and warnings they give are no substitutes for proper accident prevention measures.



WARNING: Be sure to read and understand all safety instructions in this Operator's Manual, including all safety alert symbols such as "**DANGER**," "**WARNING**," and "**CAUTION**" before using this tool. Failure to following all instructions listed below may result in electric shock, fire, and/or serious personal injury.

DAMAGE PREVENTION AND INFORMATION MESSAGES

These inform the user of important information and/or instructions that could lead to equipment or other property damage if they are not followed. Each message is preceded by the word "**NOTICE**", as in the example below:

NOTICE: Equipment and/or property damage may result if these instructions are not followed.

SAFETY INSTRUCTIONS

This page depicts and describes safety symbols that may appear on this product. Read, understand, and follow all instructions on the machine before attempting to assemble and operate.



This symbol, before a safety comment, indicates a precaution, a warning or a danger. Ignoring this warning can lead to an accident for yourself or for others. To limit the risk of injury, fire, or electrocution always apply the recommendations indicated.



Wear ear protection and eye protection when using the product.



Do not expose and operate the tool in rain.



Keep bystanders away



The fan rotates for several seconds after the Leaf Blower/ Vacuum is switched off. Keep hands away from the fan.

Warning symbols on the charger



The charger is for indoor use only.

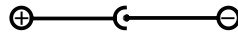

Pole orientation



Protective 5A limited



Do not expose and operate the tool in rain.

Warning symbols on the battery pack



Do not throw into water



Do not litter to fire.



Do not subject the battery to strong sunlight over long periods and do not leave it on a heater (max. 113 °F).



Li-Ion

Batteries contain Li-ion. Waste batteries should be sorted for eco-friendly. Do not dispose of waste batteries as unsorted municipal waste.



Do not expose and operate the tool in rain.



Wait until all machine components have completely stopped before touching them. The blades continue to rotate after the machine is switched off, a rotating blade can cause injury.

GENERAL POWER TOOL SAFETY WARNINGS

IMPORTANT SAFETY INSTRUCTIONS READ ALL INSTRUCTIONS BEFORE USING BLOWER



WARNING - To reduce the risk of fire, electric shock, or injury:

- a) Do not leave appliance when operating. Unplug battery pack when not in use and before servicing.
- b) Do not use on wet surfaces. Do not expose to rain. Store indoors. For household use only.
- c) Do not allow to be used as a toy. Close attention is necessary when used by or near children.
- d) Use only as described in this manual. Use only manufacturer's recommended attachments.
- e) Do not use with damaged battery pack. If appliance is not working as it should, has been dropped, damaged, left outdoors, or dropped into water, return it to a service center.
- f) Do not handle appliance, charger, including charger plug, and charger terminals with wet hands.
- i) Do not put any object into openings. Do not use with any opening blocked; keep free of dust, lint, hair, and anything that may reduce air flow.
- j) Keep hair, loose clothing, fingers, and all parts of body away from openings and moving parts.
- k) Turn off all controls before unplugging.
- l) Use extra care when cleaning on stairs.
- m) Do not use to pick up flammable or combustible liquids, such as gasoline, or use in areas where they may be present.
- n) Do not charge the unit outdoors.
- o) Do not incinerate the appliance even if it is severely damaged. The batteries can explode in a fire.

SAVE THESE INSTRUCTIONS

Personal safety

1. Stay alert, watch what you are doing and use common sense when operating a power tool. **Do not use a power tool while you are tired or under the influence of drugs, alcohol or medication.** A moment of

inattention while operating power tools may result in serious personal injury.

2. Use personal protective equipment. Always wear eye protection. Protective equipment such as dust mask, non-skid safety shoes, hard hat, or hearing protection used for appropriate conditions will reduce personal injuries.
3. Prevent unintentional starting. Ensure the switch is in the off-position before connecting to power source and/or battery pack, picking up or carrying the tool. Carrying power tools with your finger on the switch or energising power tools that have the switch on invites accidents.
4. Remove any adjusting key or wrench before turning the power tool on. A wrench or a key left attached to a rotating part of the power tool may result in personal injury.
5. **Do not overreach.** Keep proper footing and balance at all times. This enables better control of the power tool in unexpected situations.
6. Dress properly. Do not wear loose clothing or jewellery. Keep your hair, clothing and gloves away from moving parts. Loose clothes, jewellery or long hair can be caught in moving parts.

Power tool use and care

1. **Do not force the power tool.** Use the correct power tool for your application. The correct power tool will do the job better and safer at the rate for which it was designed.
2. **Do not use the power tool if the switch does not turn it on and off.** Any power tool that cannot be controlled with the switch is dangerous and must be repaired.
3. Disconnect the plug from the battery pack from the power tool before making any adjustments, changing accessories, or storing power tools. Such preventive safety measures reduce the risk of starting the power tool accidentally.
4. Store idle power tools out of the reach of children and do not allow persons unfamiliar with the power tool or these instructions to operate the power tool. Power tools are dangerous in the hands of untrained users.
5. Maintain power tools. Check for misalignment or binding of moving parts, breakage of parts and any other condition that may affect the power tool's operation. If damaged, have

the power tool repaired before use. Many accidents are caused by poorly maintained power tools.

6. Use the power tool, accessories and tool bits etc. in accordance with these instructions, taking into account the working conditions and the work to be performed. Use of the power tool for operations different from those intended could result in a hazardous situation.

Battery tool use and care

1. Recharge only with the charger specified by the manufacturer. A charger that is suitable for one type of battery pack may create a risk of fire when used with another battery pack.
2. Use power tools only with specifically designated battery packs. Use of any other battery packs may create a risk of injury and fire.
3. When battery pack is not in use, keep it away from other metal objects, like paper clips, coins, keys, nails, screws or other small metal objects, that can make a connection from one terminal to another. Shorting the battery terminals together may cause burns or a fire.
4. Under abusive conditions, liquid may be ejected from the battery; avoid contact. If contact accidentally occurs, flush with water. If liquid contacts eyes, additionally seek medical help. Liquid ejected from the battery may cause irritation or burns.
5. Use only with the battery packs and chargers listed below:

Battery pack	Charger
YF60VRX2.5-BAT	YF60VRX2A-CHG
YF60VRX4.0-BAT	YF60VRX4A-CHG

Service

- Have your power tool serviced by a qualified repair person using only identical replacement parts. This will ensure that the safety of the power tool is maintained.

CORDLESS LEAF BLOWER SAFETY WARNINGS

1. Training

- Read the instructions carefully. Be familiar with the controls and the proper use of the appliance.
- Never allow children to use the appliance.
- Never allow people unfamiliar with these instructions to use the appliance. Local

- regulations may restrict the age of operator.
- Never operate the appliance while people, especially children, or pet are nearby.
- The operator or user is responsible for accidents or hazards occurring to other people or the property.

2. Preparation

- While operating the appliance, always wear substantial footwear and long trousers.
- **Do not wear loose clothing or jewellery that can be drawn into the air inlet. Keep long air away from the air inlet.**
- Wear protective goggles while operating.
- To prevent dust irritation the wearing of face mask is recommended.
- Before using, always visually inspect the rotating parts. Replace worn or damaged part in sets.
- **Never operate the appliance with defective guards or shields, or without safety devices.**

3. Operation

- Switch the motor off and remove the battery pack
- whenever you leave the machines;
 - before clearing a blockage;
 - before checking, cleaning or working on the appliance;
 - if the appliance starts to vibrate abnormally
- Operate the appliance only in daylight or in good artificial light.
- Do not overreach and keep your balance at all times.
- Always be sure of your footing on slopes.
- Walk, never run.
- Keep all cooling air inlets clear of debris.
- Never blow debris in the direction of bystanders.
- Operate the machine only at reasonable hours – not early in the morning or late at night when people might be disturbed. Comply with times listed in local ordinance.
- Operate the machine at the lowest possible engine speed to do the job.
- Use rakes and brooms to loosen debris before blowing.
- In dusty conditions, slightly dampen surfaces or use mister attachment if available.
- Use the full blower nozzle extension so the air stream can work close to the ground.
- Watch out for children, pets, open windows etc. and blow debris safely away.

- Do not start the tool when it is upside down or when it is not in the operating position.
- Switch the motor off and remove the battery pack when the tool is not being used. Left unattended, being cleaned, being moved from one place to another.
- Do not handle the tool with wet hands and do not use the tool in the rain.
- Do not switch on the tool in enclosed or poorly ventilated spaces or in the presence of inflammable and/or explosive substances such as liquids, gasses and powders.
- Do not get distracted and always concentrate on what you are doing. Use common sense. Never operate the tool when you are tired, sick or under the influence of alcohol or other drugs.

4. Maintenance and storage

- Keep all nuts, bolts and screws tight to be sure the appliance is in safe working condition.
- Check the debris collector frequently for wear or deterioration.
- Do not try to repair the tool or access internal parts. Contact authorised service centers only.
- Replace worn or damaged parts.
- Use only genuine replacement parts and accessories.
- Store the appliance only in a dry place.

Special Operation safety for the charger

1. Recharge only with the charger specified by the manufacturer. Do not use the original charger on other li-ion batteries or on any other type of battery—fire or explosion may occur.
2. Check the battery charger, cable and plug each time before using. Do not use the battery charger when defects are detected. Do not open the battery charger yourself and have it repaired only by qualified personnel using original spare parts.
3. The charger is designed to use standard household 100-240 V, 50/60 Hz power source. The charger's plug must match the outlet. Never modify the plug in any way. Unmodified plugs and matching outlets will reduce risk of electric shock.
4. Do not abuse the cord of charger. Never use the cord for carrying, pulling or unplugging the charger. Keep cord away from heat, oil, sharp edges or moving parts. Damaged or entangled cords increase the risk of electric

- shock.
5. Make sure the charger cord is located so that it will not be stepped on, tripped over, or otherwise subjected to damage or stress.
6. Keep the battery charger clean. Contamination may cause the danger of electric shock.
7. Protect the battery charger from rain and moisture. The penetration of water in a battery charger increases the risk of electric shock.
8. Do not operate the battery charger on easily inflammable surfaces (e.g. paper, textiles, etc.) or in combustible environments. There is danger of fire due to the heating of the battery charger during charging.
9. The temperature range over which the battery pack can be charged is typically 41 °F - 113 °F. Therefore, charging efforts outside the prescribed temperature range may automatically be blocked by the protection circuitry of the battery pack. Longest life and best performance can be obtained if the battery pack is charged in the normal room condition.
10. Disconnect charger from the power supply when not in use. This will reduce the risk of electric shock or damage to the charger if metal items should fall into the opening.
11. The charger is for indoor use only.

Special Operation safety for the battery pack

1. The Li-ion battery pack is not fully charged at the factory. Before attempting to use it ,it must be fully charged firstly.
2. The battery pack should be recharged when it fails to produce sufficient power on jobs which were easily done previously. DO NOT CONTINUE using product with its battery in a depleted condition.
3. Do not charge the battery in an air temperature below 41 °F or above 113 °F. This is important and will prevent serious damage to the battery. Longest life and best performance can be obtained if the battery is charged when air temperature is about 68 °F.
4. When the machine continues to be used and the battery temperature is above 113 °F, the battery can not be charged, even you put on the charger. Let the machine cool for some times and wait the temperature reduced, it can be charged again .
5. Protect the battery pack against heat, e.g. including against continuous sun irradiation and fire. There is a danger of explosion.

6. Do not carry individual battery packs in your pockets or bags, as they could short-circuit against other metal items.
7. If an exposed li-ion battery pack does start a fire, it will burn even more violently if it comes into contact with water or even the moisture in the air. DO NOT throw water on a burning li-ion battery! A fire extinguisher must be used.
8. If the battery pack becomes too hot to the touch during charging, disconnect and switch off immediately. Contact Service Centre directly.
9. Do not open the battery yourself. There is danger of a short circuit.
10. When battery pack is not in use, keep it away from other metal objects, like paperclips, coins, keys, nails, screws or other small metal objects, that can make a connection from one terminal to another. Shorting the battery terminals together may cause burns or a fire.

**WARNING:** Battery posts, terminals

and related accessories contain lead and lead compounds, chemicals known to the State of California to cause cancer and birth defects or other reproductive harm. Wash hands after handling. For more information, go to www.P65Warnings.ca.gov.

ASSEMBLY**Assembling the lower tube to upper tube
(See Fig. 3)****WARNING:** Before performing any

assembly. Always ensure that the battery pack has been removed.

1. Select the lower tube nozzle type – round or flat.
 - Round nozzle for general blowing.
 - Flat nozzle for concentrated blowing
2. Aligning the slot on the lower nozzle you chosen with raised post on the upper tube.
3. Push them against each other.
4. Twist the lower nozzle clockwise.
5. Make sure that the nozzle is securely fitted with upper tube.

OPERATION**Inserting and removing the battery pack****To insert the battery pack**

1. Align the groove on the battery pack with the corresponding mounting ribs and press the battery pack down until you hear a “click”.
2. Check to make sure the battery pack is firmly secured into position.

To remove the battery pack from the tool (See Fig. 4)

1. Depress the releasing/locking button on the housing.
2. The battery pack will pop up automatically.
3. Lift and hold the battery pack while pressing the releasing/locking button again, and then remove the battery pack.

ATTENTION: Battery Installation

INSTALLATION: Battery lock has 2 positions. Press down firmly until battery is fully inserted.

REMOVAL: Press release button once, hold battery firmly, press release button again, Pull battery out.

Switch ON/OFF**To switch ON**

1. Depress the switch trigger on the underside of the main handle. (See Fig. 5-A)

To switch OFF

1. Release the switch trigger.

NOTE: You can not pull out the switch trigger when lock on cruiser lock lever is at downward position. Make sure that the cruiser lock lever is at default position before you switch on the blower.

Usage of the cruiser lever (See Fig. 5-B)

The cruise control feature allows you to lock the blower on continuously for extended periods of time.

Turbo function (See Fig. 6)

1. Press the turbo button on the control panel can start the turbo function, When the turbo function

is activated, the LED above the corresponding button will light up, and the color of the light will be white.

2. The turbo function will last for 30 seconds then automatic turned off, if continue use the turbo function, press again.

Speed adjustment (See Fig. 7)

Three speed settings allow to be changed with a touch of the button on the control panel.

1. Press the speed adjustment button and set to your selected blow speed.
2. If the speed is set to the highest, press the speed adjust button again and this will reduce the speed.
3. When adjusting the speed, the LED above the corresponding buttons will change to different colors. The blue LED indicates the lowest speed, the white LED indicates the medium speed, and the green LED indicates the maximum speed.

NOTE: This blower has the speed memory function, with the battery pack was kept in position. The speed setting of next use can be kept the same as previous use.

Transport

Use the original packaging to ship whenever possible.

STORING AND MAINTENANCE



WARNING !

Before performing any repair work, always remove the battery pack and wait until the motor has come to a standstill.

1. Do not spray the blower with water. Ingress of water may destroy the battery pack and the electric motor.
2. Clean the blower with a cloth, hand brush, etc.
3. Keep all nuts, bolts and screws tight to be sure the equipment is in safe working condition;
4. Replace worn or damaged parts for safety.

Storage:

1. Clean the exterior of the blower thoroughly using a soft brush and cloth, Do not use water, solvents or polishes.
2. Store the machine in a dry place. Do not place other objects on top of the machine.

TROUBLE SHOOTING

 **WARNING !**

Before performing any repair work, always ensure that the battery pack/safety key has been removed and wait until the tool has stopped completely.

 **WARNING !**

Always wear heavy duty gloves when adjusting or cleaning.

Fault/malfunction	Cause	Remedy
Blower fails to operate Battery.	Battery discharged?	Charge battery.
	Battery pack not fitted correctly.	Remove and re install the battery pack.
	Garden tool is too hot.	Allow tool to cool and try again.
	Device defective.	Contact service partner.
Tube cannot be assembled on the machine.	Incorrect assembly .	remove the tube and re assemble correctly.
AIR Speed is low.	Debris blocking air inlet vents.	Remove the battery and then check/ clear debris from tube and vents.
	Battery pack has low charge.	Recharge battery.

WARRANTY

Product Warranty

Please keep your original purchase receipt in a safe place as proof of purchase.

Warranty coverage for this product must be verified by the original purchase receipt.

The warranty period begins on the day that the product was purchased from an authorized retailer of Yard Force products. Warranty coverage only applies to the original purchaser and is not transferrable.

Warranty coverage is only provided on products purchased from authorized Yard Force retailers.

Warranty only applies to products purchased and OPERATED in the USA. Any product purchased or operated outside of the USA is not covered by any warranty.

(1) Five-Year Warranty on Yard Force Outdoor Power Equipment and Three-Year Warranty on 60vRX Battery Pack and Charger

The Yard Force Outdoor Power Equipment has a Five-Year Limited Warranty and 60vRX Battery Pack and Charger has a Three-Year Limited Warranty from the date of purchase against manufacturer defects for residential use only. Commercial use voids the warranty. This warranty does not cover accidental damage, unreasonable use, normal wear and tear, neglect or non-compliance with the Operating, Safety and Maintenance Instructions. All service, outside of normal maintenance as described in this manual, must be done by an authorized service technician. Any unauthorized service or changes to the original configuration of this product will void the warranty. All parts and accessories used on and with this product must be manufactured and/or authorized by Merotec Inc.

(2) Ninety-Day Warranty – Accessories

The accessories included with the machine including the tube and other similar parts are warranted against manufacturer defects for residential use only for a period of 90 days from date of purchase.

Warranty does not cover loss of use or other consequential damages arising from any of the above, nor does it cover repairs made or attempted by unauthorized persons.

This warranty is void if the product is used for commercial, rental or industrial purposes.

Certain parts, attachments and accessories are subject to normal wear and tear and are excluded from the warranty.

Service and Warranty Claims Process

Contact the Yard Force Support Center toll-free at **(866) 902-9690 Monday-Friday between 8:30 AM and 5:00 PM Eastern Time** for service and warranty support.

Yard Force Service Support agents can help you troubleshoot problems over the phone to get you back up and running as quickly as possible. In the situation where service or warranty inspection is needed, please follow these steps:

1. Call Yard Force at **(866) 902-9690 Monday-Friday between 8:30 AM and 5:00 PM Eastern Time**.
2. Send in proof-of-purchase and serial number (if applicable) to confirm warranty Coverage as directed by Yard Force.
3. If service or a warranty evaluation is requested, Yard Force will provide an RGA number that should be used in all communications with Yard Force and is required to be indicated on the product itself and on the outside of the box.
4. All shipments to Yard Force must have an RGA number. Any shipment received that does not have an RGA number clearly marked on the outside of the box will be refused.
5. All shipments must be sent pre-paid, Yard Force does not pay for any shipping costs for service or warranty evaluation. Yard Force is not responsible for any packages that are lost by carrier. We recommend that shipments are made by a carrier that provides tracking and delivery confirmation.

For more information or to ask questions, please call toll-free **(866) 902-9690 Monday-Friday between 8:30 AM and 5:00 PM Eastern Time**.

SAVE THESE INSTRUCTIONS

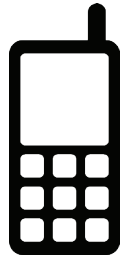

1-866-902-9690



support@merotecusa.com

Need Help?

**Please do not return the product to the place of purchase yet.
We're here to help and take care of all your needs.**

Contact our Customer Care Center in Atlanta, GA for help with:

- **Product assembly or use**
- **Missing or damaged parts**
- **Troubleshooting**

**You can also visit our website to download
owner's manuals and get additional product information.
Visit www.YardForceUSA.com, or call our
toll free hotline: 1-866-902-9690 M-F 8:30am – 5:00pm ET**